

City Lab

fernhay.

 vorboss

Explore how the unique combination of skills and knowledge from both firms has led to the creation of CityLab.

An innovative solution designed to redefine city travel and on-site field capabilities, is the result of a groundbreaking collaboration between Fernhay and Vorboss. This partnership combines Fernhay's urban logistic and manufacturing expertise with Vorboss's design, engineering, and telecommunications prowess, making CityLab a reality today.



Revolutionizing utility servicing

Discover the features of the CityLab, crafted over months of dedication and ingenuity. Its practical design enables technicians to conduct fieldwork efficiently, with a secure cargo section and pull-out workspaces. The eco-friendly operations of the CityLab significantly lower costs and emissions, making it an economically and environmentally sound choice for urban logistics.



The CityLab is designed with both practicality and safety in mind, featuring a volume divided into two distinct compartments:

The store

This is dedicated to storing tall and bulky equipment essential for initial site setup. It can accommodate large equipment such as barriers and sandbags ensuring technicians have everything they need to prepare the site efficiently and safely.



The Lab

The lab functions as a secure mobile workshop, equipped with storage for all necessary tools and equipment for various tasks. It also includes work platforms, providing a convenient, organized, and secure space for technicians to perform their work on-site.

Versatile and Secure

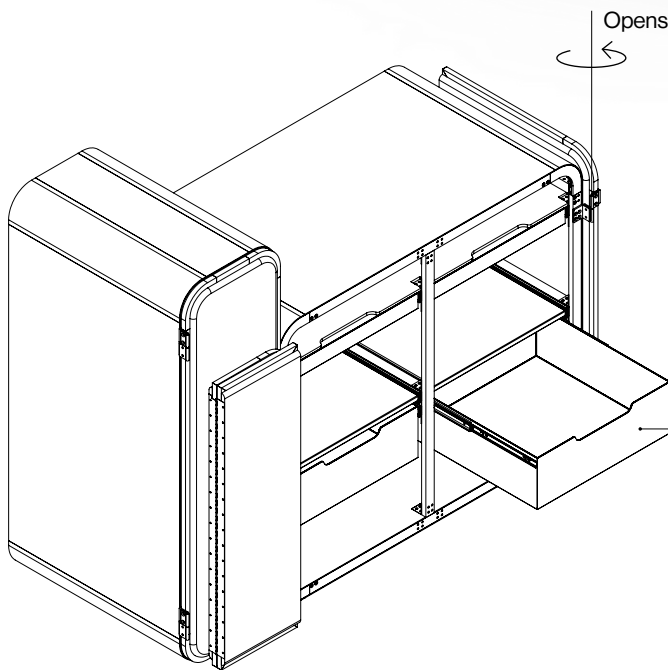

Opens 270° and locks

The arrangement of drawers allows heavy equipment to be lifted with minimal effort.

This drawer is locked with a key keeping the most expensive equipment safe during transit and when working on site.

Versatile and Secure

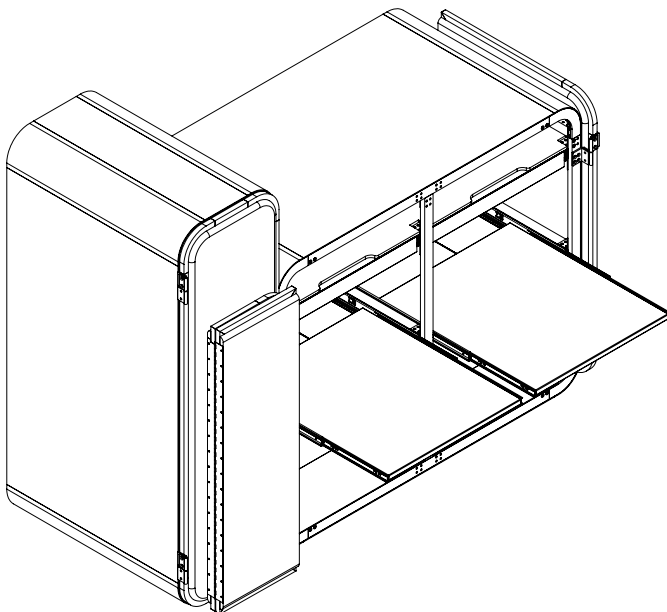

The platforms are made to accommodate a wide variety of technician heights and are positioned at the ideal operating height.

Technical data

Dimensions	302 cm(L) x 91 cm (W) x 195 cm(H)
Range	up to 50 km
Vehicle weight	280 kg

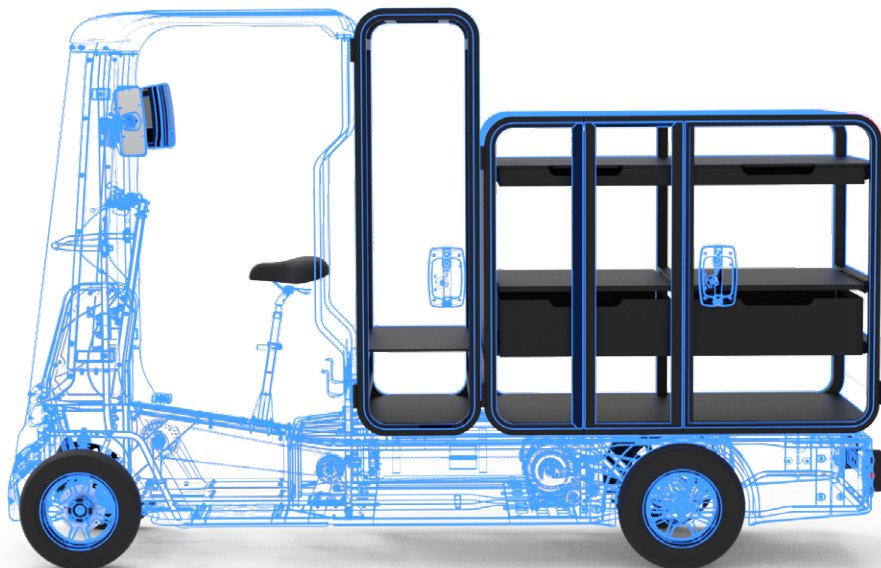

City Lab

fernhay.

 vorboss

